

# PRODUCT SHEET PRL

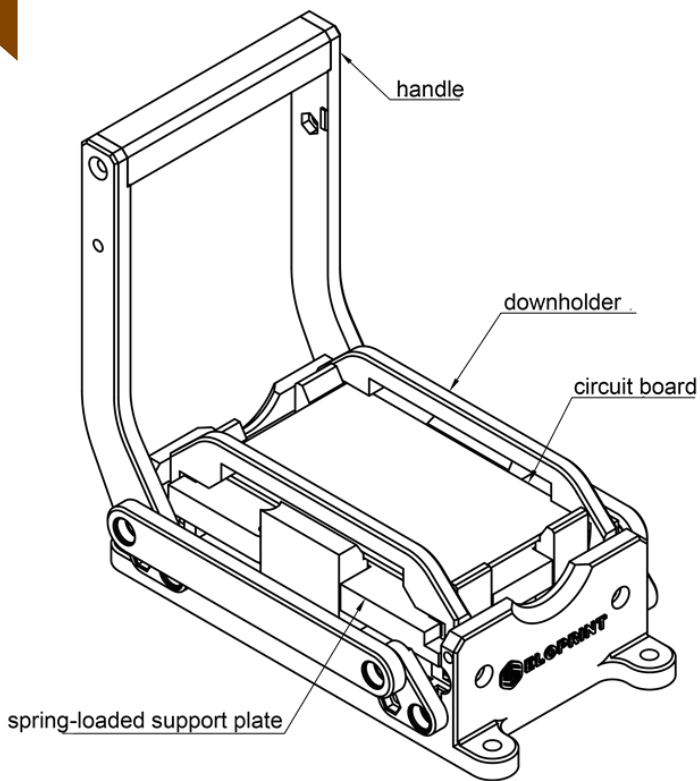

- + Ideal for small or medium sized rectangular PCBs.
- + The top of the test specimen is freely accessible when closed.
- + On request with integrated end switches, plugs, switches, display elements, fans, etc.
- + Long service life and easily replaceable wear parts.
- + Individually tailored to your circuit board geometry adjusted. High and protruding components are taken into account.

CHARACTERISTIC	STANDARD	SPECIAL CASE
Usable area	Adapted to the size of the test specimen	—
Temperature max.	50°C, 90°C or 120°C	High-performance plastic: >200°C in extreme cases, the test adapters can be made of metal or ceramic
Temperature min.	-20°C	—
ESD protection	Guaranteed by special coating	—
Contact resistance	< 50 mΩ	< 4 mΩ
Current strength	1 Ampere	> 100 Ampere
Interface	freely configurable	—
High frequency	No special precautions	Special coaxial test pins, cables and connectors
Lifespan	> 100,000 cycles (often much more in practice)	—
Pitch	≥ 1,27 mm	≥ 0.5 mm (requires closer inspection)
Contact force max.	300 N	—
Linear stroke	100 mm	—
Material	FR2, PLA, ABS oder PC	Aluminum, steel, PA12, ASA, PEEK, PEI, ceramic or acrylic resin
Conformity	RoHS-3	—

